

# BT Synergy 5100 User Guide



Bringing it all together



# Welcome

to your BT Synergy 5100  
Digital Cordless Telephone

- Display with blue backlight.
- 250 Name and number phonebook.
- Copy phonebook entries between other handsets or your mobile phone SIM card.
- Send and receive text messages.<sup>1</sup>
- Caller Display shows you who's calling and see details of the last 30 callers in a Calls list.<sup>2</sup>
- Register up to 5 handsets to a single base.
- Make internal calls, transfer external calls, hold 3-way conversation between two internal callers and an external caller.

1 You must subscribe to your network provider's Caller Display Service for text messaging to work and you must not withhold your telephone number. A quarterly fee may be payable. Some other network provider lines may not be compatible with this text messaging service.

2 You must subscribe to your network provider's Caller Display or Call Waiting service for these features to work. A quarterly fee may be payable.

Please note that this equipment is not designed for making emergency telephone calls when the power fails. Alternative arrangements should be made for access to emergency.

This User Guide provides you with all the information you need to get the most from your phone.

Before you make your first call you will need to set up your phone. Follow the simple instructions in 'Getting Started', on the next few pages.

#### **Need help?**

If you have any problems setting up or using your BT Synergy please call our free Helpline on 0800 145 6789\* or email [bt.helpdesk@sgweurope.com](mailto:bt.helpdesk@sgweurope.com). Our dedicated advisers are more likely to be able to help you than the retailer where you made your purchase.

Alternatively, you may find the answer in the 'Help' section at the back of this guide.

#### **IMPORTANT**

Only use the telephone line cord supplied.

\* Calls made from within the UK mainland network are free. Mobile and international call costs may vary.

#### **Got everything?**

- BT Synergy 5100 base
- BT Synergy 5100 handset
- 2 x AAA NiMH rechargeable batteries
- Mains power adaptor for the base (item code 040497)
- Telephone line cord

**If you have purchased a BT Synergy 5100 multiple pack you will also have the following items for each handset:**

- BT Synergy 5100 handset & charger
- 2 x AAA NiMH rechargeable batteries
- Mains power adaptor for charger (item code 032765)

# In this guide

## Getting started

Location.....	6
Setting up .....	6
Setting up for multiple packs .....	7
Date and time.....	8
Removing the batteries .....	8

## Getting to know your phone

Handset buttons .....	9
Standby screen .....	10
Display icons .....	10
Base.....	11
Navigating the menus .....	11
Menu map/character map .....	12

## Using the phone

Switch the handset on / off.....	14
Make a call .....	14
Preparatory dialling .....	14
End a call.....	14
Receive a call .....	14
Adjust the earpiece/receiver volume .....	15
Secrecy .....	15
Make a handsfree call.....	15
Answer a call handsfree.....	15
Switch to handsfree during a call .....	15
Redial the last number called .....	15
Redial a number from the redial list.....	16
Save a number from the redial list to the phonebook.....	16
Delete a / all redial number (s) .....	16
To lock/unlock the keypad .....	16
Paging/Find handset.....	16
250 Name and number phonebook .....	17
Store a name and number .....	17
View an entry .....	17
Dial an entry.....	17
Edit a name and number .....	18

Edit ringtone .....	18
Delete an entry.....	18
Delete entire phonebook.....	19
Copy an entry to another handset .....	19
Copy the entire phonebook to another handset .....	19
Copy an entry to a SIM card .....	20
Copy all entries to or from a SIM card .....	20
Change the dialling code .....	21

## Handset settings

Handset ringtone.....	22
Handset ringer volume.....	22
Receiver volume .....	22
Handset name .....	23
Display language .....	23
Light timeout .....	23
Auto talk .....	24
Key beep .....	24
PABX access code .....	24

## Base settings

Base ringtone .....	25
Base ringer volume .....	25
Dialling mode .....	25
Ring priority .....	26
Recall mode .....	26
First ring .....	27
System PIN.....	27
Restore default settings .....	27

## Clock & alarm

Date & time .....	28
Set alarm.....	28
Alarm on /off.....	28
Time format.....	29
Switch off alarm ring.....	29

## Agenda

Add a new event.....	30
Switch off agenda ring .....	30
Show agenda details .....	31
Edit agenda.....	31
Send agenda as a text message.....	32
Delete agenda .....	32
Delete all agendas.....	32

## Calls lists

Caller Display / Calls lists.....	33
View new missed calls .....	33
View and dial from a calls list .....	34
Copy a Calls list number to the phonebook .....	34
Send a text message to a Calls list number .....	34
Delete an entry .....	35
Delete all entries.....	35

## Call Waiting ..... 36

## BT Services

BT Helpline.....	37
BT 118500 (Directory Enquiries) .....	37
Call Divert on/off/check .....	38
Call Waiting on/off/check .....	38
Add or edit an entry .....	38
Dial a stored entry.....	39
Delete an entry.....	39
Delete all entries.....	39

## Text messaging

Subscribe to the text messaging service .....	40
Cost of the fixed line service .....	40
Send a text message .....	40
Receiving and reading text messages .....	41
Read a new message.....	42

Read, forward, delete, view and save numbers of texts in the Inbox.....	42
Edit or send texts in the Drafts box.....	43
Forward or delete texts in the Outbox .....	44
Edit templates .....	44
Deleting texts .....	45
Service Centre numbers.....	45
Add or change Service Centre numbers .....	45
Set send centre.....	46
Message alert tone .....	46
Set message size .....	46

## Using additional handsets

Registering an additional handset.....	47
Select a base .....	48
De-register a handset .....	48
Internal calls.....	49
Call another handset .....	49
Transfer a call.....	49
3-way conference call .....	49

## Help..... 50

## General information

Safety information .....	56
Cleaning.....	56
Environmental.....	56
Product disposal instructions .....	57
Guarantee .....	57
Returning your phone .....	58
How many telephones can I have? .....	58
R&TTE.....	58
Declaration of Conformance .....	58
Connecting to a switchboard .....	58
Inserting a pause .....	58
Recall.....	58

# Getting started

## WARNING

Do not place your BT Synergy 5100 in the bathroom or other humid areas.

## Handset range

The BT Synergy 5100 has a range of up to 300 metres outdoors when there is a clear line of sight between the base and handset. Any obstruction between the base and handset will reduce the range significantly. With the base indoors and handset either indoors or outdoors, the range will normally be up to 50 metres. Thick stone walls can severely affect the range.

## Signal strength

The **Y** icon on your handset indicates when you are in range. When out of range of the base the **Y** icon will flash and the out-of-range tone will sound every minute. This tone is repeated until you move back into range.

## IMPORTANT

The base station must be plugged into the mains power at all times. Do not connect the telephone line cord into the wall socket until the handset is fully charged. Only use the power and telephone cables supplied with the product.

## Location

You need to place your BT Synergy 5100 base within 2 metres of the mains power socket and telephone socket so that the cables will reach.

Make sure it is at least 1 metre away from other electrical appliances to avoid interference. Your BT Synergy 5100 works by sending radio signals between the handset and base. The strength of the signal depends on where you site the base. Putting it as high as possible ensures the best signal.

## Setting up

Connect the base

1. Plug the mains power cable into the socket marked **P** on the underside of the base and plug the other end into the mains power wall socket and switch the power on.

The telephone cable is pre-installed in the base but do not connect the other end to the telephone wall socket yet.

Telephone line cord  
(pre-installed)

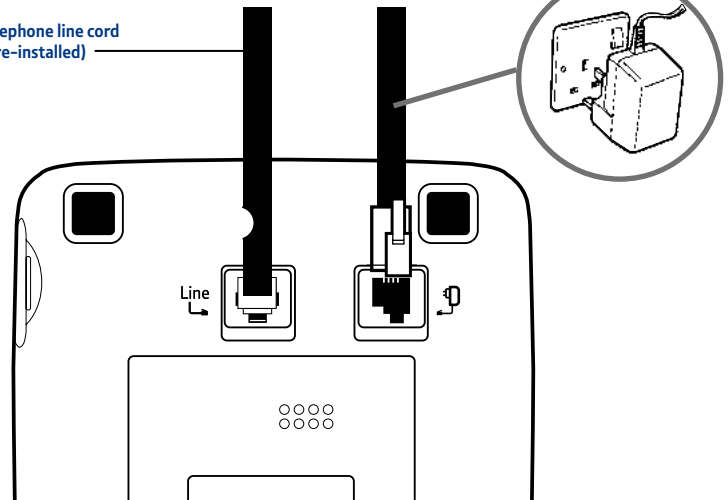

2. Make sure the battery ribbon is laying flat inside the compartment and insert the two batteries supplied observing the polarity markings (+ and -).
3. Attach the battery compartment cover by sliding the ends into the holes inside the compartment, pressing down and pushing the other end along until it clicks into place.
4. Place the handset on the base to charge for at least 24 hours. The red charging light comes on. When the handset is fully charged the display shows the  icon.
5. After 24 hours, plug the telephone line cord from the base into the telephone wall socket.

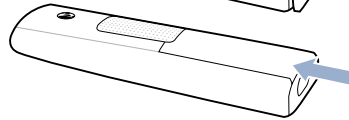
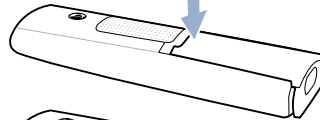
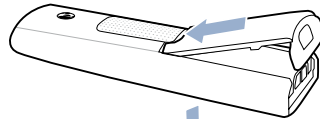
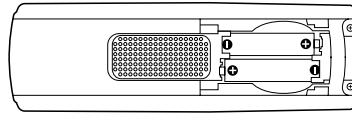

### Setting up for multiple packs

If you have purchased a multiple pack, this process will need to be carried out for all handsets and chargers:

1. Plug the mains power cable into the socket marked  on the underside of the charger.

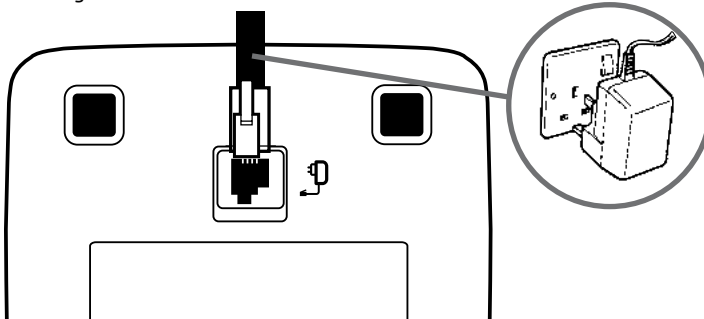

### Battery low warning

If the  icon flashes in the external display you will need to recharge the handset before you can use it again.

During charging, the  icon will scroll in the display.

### Battery performance

In ideal conditions, fully charged batteries should give about 10 hours talk time or 100 hours standby time on a single charge.

Note that new batteries do not reach full capacity until they have been in normal use for several days.

To keep your batteries in the best condition, leave the handset off the base for a few hours at a time.

Running the batteries right down at least once a week will help them last as long as possible.

The charge capacity of rechargeable batteries will reduce with time as they wear out, giving the handset less talk/standby time. Eventually they will need to be replaced. New batteries are available from the BT Synergy Helpline on 0800 145 6789\*.

After charging your handset for the first time, subsequent charging time is about 6–8 hours a day. Batteries and handset may become warm during charging. This is normal.

2. Insert the batteries as described previously above.
3. Place the handset on the charger to charge for at least 24 hours. When the handset is fully charged the  icon will indicate that it is fully charged.

## Your BT Synergy 5100 is ready for use.

### **Date and time**

Providing you have subscribed to your network's Caller Display service, the date and time is set automatically for all handsets when you receive your first call. The date and time is recorded with each call you receive.

If you do not have a Caller Display service you can set the date and time manually. Please see page 30 for these instructions.

### **Removing the batteries**

If you ever need to remove the batteries, simply slide open the battery compartment cover and pull the ribbon away from the handset to release the batteries.

## Handset buttons

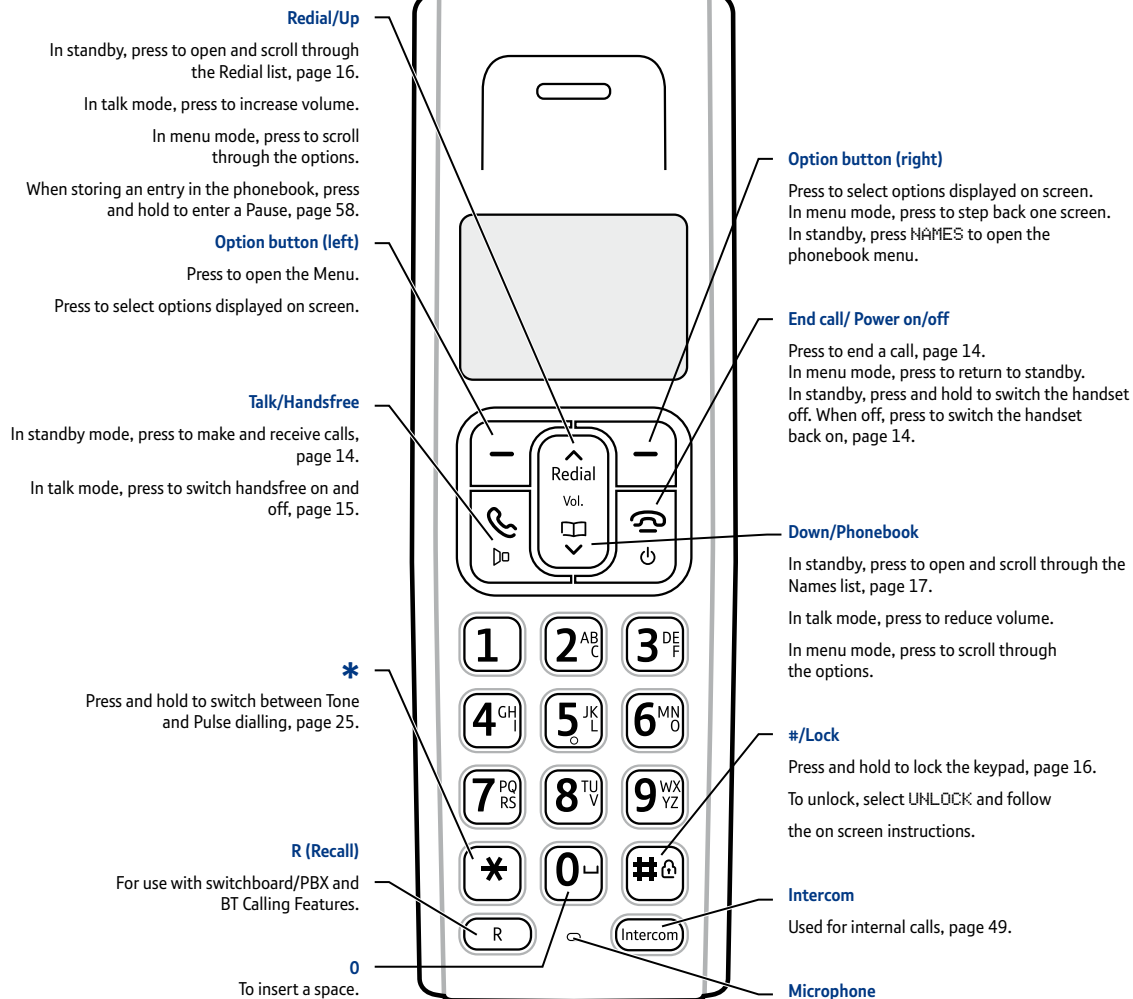



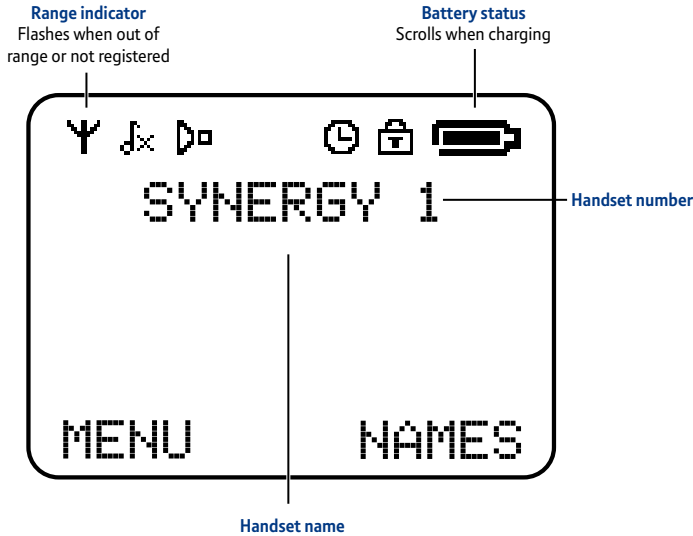

## Standby screen

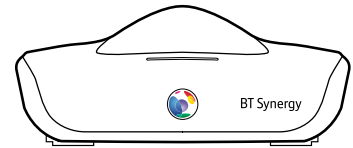





## Charger



## Display icons

-  Displayed in standby mode to indicate handset is in range of the base. Flashes if you move out of range.
-  Shows handset battery status.
-  Scrolls when the handset is charging.
-  Scrolls when the handset is charging.
-  Handset ringer volume is Off.

-  Displayed in handsfree talk mode.
-  An alarm is set.
-  The keypad is locked.
-  You have SMS text messages.\*†
-  You have missed calls.\*†

\* For this feature to work you must subscribe to your network provider's Caller Display service. A fee may be payable.

† The number underneath the icon indicates the number of messages or the number of missed calls received.

## Base

### Find

Press to ring all registered handsets, helpful for finding a missing handset, page 16.

**Battery charging light (red)**  
On=handset charging on base.

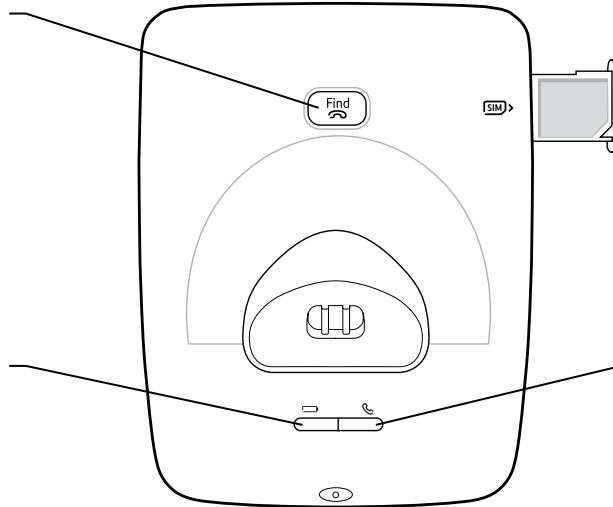

**SIM Card slot**  
See page 20.

**Power / In use light (green)**  
On=power on.  
Flashes=base in use.

### Option buttons

Press to select the option displayed on the screen.

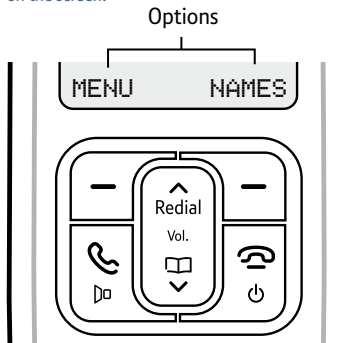



If no buttons are pressed for 30 seconds, the handset returns to standby automatically.

## Navigating the menus

Your BT Synergy 5100 has an easy to use menu system.

Each menu has a list of options, which you can see on the menu map on the following page.

When the handset is switched on and in standby:

1. Press MENU to open the main menu.
2. Then use  or  buttons to scroll through the available options.
3. Press the SELECT option button to select a menu option or the BACK option button to go back to the previous screen.

To return to the previous menu level, press BACK.

To exit the menu and return to standby press .

## Menu map

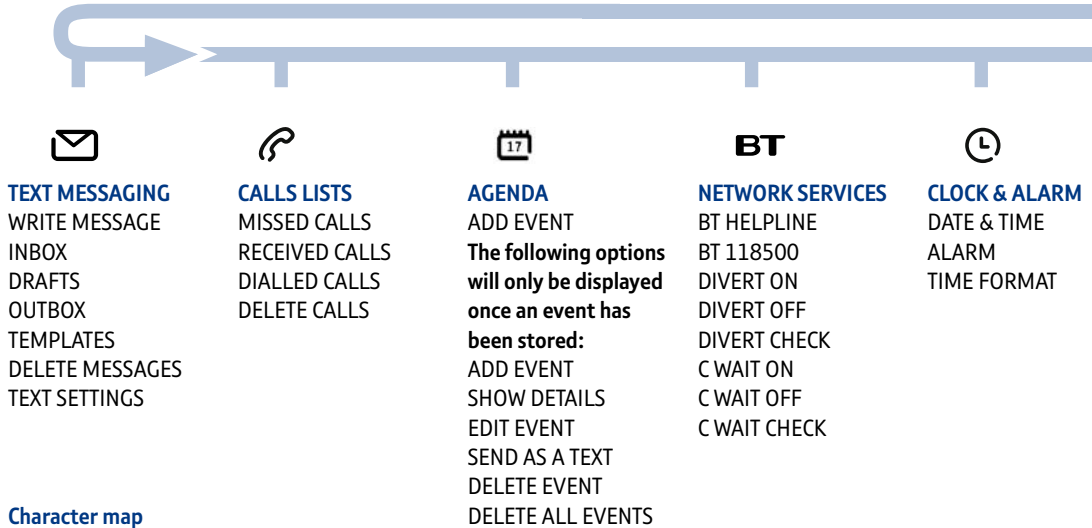

## Character map

Button	Lowercase	Uppercase
1	. , - ? ! i ' @ : ; / 1	
2	a b c 2 ä æ å à ç	A B C 2 Ä Æ Å Ç
3	d e f 3 è é	D E F 3 É
4	g h i 4 ì	G H I 4
5	j k l 5	J K L 5
6	m n o 6 ö ø ò ñ	M N O 6 Ö Ø Ñ
7	p q r s 7 ß	P Q R S 7
8	t u v 8 ù ü	T U V 8 Ü
9	w x y z 9	W X Y Z 9
0	0 □ (= space)	
*	bring up symbol table (in SMS text editing mode)	
#	short press to switch between Abc, abc, ABC and 123 mode	



### SETTINGS

SET HANDSET  
 RINGTONE  
 RINGER VOLUME  
 RECEIVER VOLUME  
 HANDSET NAME  
 LANGUAGE  
 SCREENSAVER  
 LIGHT TIMEOUT  
 AUTO TALK  
 KEY BEEP  
 PABX ACCESS CODE  
 SET BASE  
 RINGTONE  
 RINGER VOLUME  
 DIALLING MODE  
 RING PRIORITY  
 RECALL MODE  
 FIRST RING  
 SYSTEM PIN  
 MASTER RESET



### REGISTRATION

REGISTER HANDSET  
 SELECT BASE  
 DE-REGISTER

### NAMES menu

From menu in standby:  
 SEARCH  
 ADD ENTRY  
 COPY PHONEBOOK  
 DIALLING CODES  
 MEMORY STATUS  
 DELETE PHONEBOOK

Press  in standby:

PHONEBOOK EMPTY will be displayed if no entries are stored.

Select **OPTIONS** and the following list is displayed:

SHOW DETAILS  
 SEND MESSAGE  
 EDIT ENTRY  
 COPY ENTRY  
 RINGTONE  
 DELETE ENTRY

### Press **NAMES** during a call:

Phonebook list is displayed.  
 ADD ENTRY  
 SHOW DETAILS  
 EDIT ENTRY  
 DELETE ENTRY

# Using the phone

When you make a call, the green In Use light on the base flashes.

## Call timer

Your handset will automatically time the duration of all external calls. The handset display shows the call duration both during and for a few seconds after your call.

During a call, you can open the phonebook by pressing NAMES.

## Out of range warning

When the handset moves out of range of the base, the screen shows SEARCHING... the  flashes and the handset gives a warning beep.

If you are on a call, the line will hang up. Move back within in range. The handset will automatically re-connect to the base.

## Auto Talk

If auto talk is set to ON you can just pick the handset up to answer a call.

If you have switched auto talk off, you will need to press  as well.

Auto Talk ON is the default setting. To switch Auto Talk on and off, see page 24.

## Switch the handset on / off

1. In standby, press and hold  to switch the handset off.

When off, press  to switch back on, or put the handset back on its base.

## Make a call

1. Press .
2. When you hear the dial tone, dial the number.

## Preparatory dialling

1. Dial the number first. If you make a mistake press CLEAR to delete the last digit.
2. Press  to dial.

## End a call

1. Press .

## Receive a call

When you receive an external call, the phone rings. The display shows EXTERNAL CALL and the caller's number or, if the number matches an entry stored in the phonebook, the name is displayed.

### To answer the call:

1. If your handset is on the base and Auto Talk is on, pick up the handset.

Or

If your handset is on the base and Auto Talk is off, pick up the handset and press .

Or

If your handset is off the base, press .





### Adjust the earpiece /receiver volume

1. During a call, press  or  to increase the volume. The display shows the level.

### Secrecy

1. During a call, press **SECRECY**. The display shows **SECRECY ON** and your caller cannot hear you.
2. Press **OFF** to return to your caller.

### Make a handsfree call



1. Dial the number then press .
2. Press  again. The  icon is displayed and you hear your call over the handset loudspeaker.  
Press  to switch the call between the earpiece and the loudspeaker.
3. Press  to end the call.

### Answer a call handsfree



When the phone rings:

1. Press  twice to answer the call.

### Switch to handsfree during a call

1. During a call: press  to put the call on the loudspeaker. To switch handsfree off and return the call to the earpiece, press  again.

### Redial the last number called

1. Press  the last number you called is highlighted.
2. Press  to dial.



There are 8 volume settings, the default setting is level 1.

#### Secrecy

During a call, you can use the secrecy function to talk to someone nearby without your caller hearing.

#### Handsfree

Handsfree lets you talk to your caller without holding the handset. It also enables other people in the room to listen to your conversation over the loudspeaker.

During a handsfree call, press  or  to change the volume.

#### Redial

The last 20 telephone numbers called are saved to a redial list. You can then select any of the numbers to redial, delete or copy to the phonebook.

Redial numbers can be up to 32 digits long.

**Keypad lock**

You can lock the keypad so that it cannot be used accidentally while carrying it around.

You will be able to dial the emergency numbers 999 and 112.





**Important**

When the keypad is locked you can still answer incoming calls and operate the handset as normal. When the call is ended, the keypad lock comes on again.

You can alert a handset user that they are wanted or locate a missing handset.

Paging calls cannot be answered by a handset.

**Redial a number from the redial list**

1. Press  the last number you called is displayed.
2. Press  or  to scroll to the number you want.
3. Press  to dial.

**Save a number from the redial list to the phonebook**

Please see page 34 for instructions, “Copy a Calls list number to the phonebook”, and select the Dialed calls option.

**Delete a redial number/delete all redial**

Please see page 35 for instructions and select the DIALLED CALLS option.



**To lock the keypad**

1. Press and hold . The  icon is displayed.

**To unlock the keypad:**



1. Press UNLOCK. Display shows PRESS # TO UNLOCK KEYS.
2. Press  within a second.

**Paging/Find handset**



1. Press  on the base. All handsets registered to the base will ring and display PAGING CALL.
2. Press  on the base again to stop the ringing or, on any handset, press STOP or any button on the handset to stop all handsets ringing.

## 250 Name and number phonebook





### Store a name and number

1. From standby, press **NAMES**. The phonebook menu is displayed.
2. **SEARCH** is highlighted. Scroll  to **ADD ENTRY** and press **SELECT**.
3. Enter the name and press **OK**.
4. Enter the number and press **SAVE**.
5. Scroll  or  to the ringtone you want and press **SELECT**. The display shows <NAME> **SAVED** and returns to the phonebook menu.
6. Press **BACK** to return to the previous menu level.

### View an entry

1. Press . The first entry is displayed.
2. Scroll  or  to the entry you want or search alphabetically.
3. Press **OPTIONS**. The display highlights **SHOW DETAILS**.
4. Press **SELECT** to display the name, number and ringtone.
5. Press **DIAL** to call the number or **BACK** to return to the previous level.

### Dial an entry

1. In standby, press . The first entry is displayed.
2. Scroll  or  to the entry you want or search alphabetically.
3. Press  to dial the displayed number.

You can store up to 250 names and numbers in the phonebook. Names can be up to 12 characters long and numbers up to 24 digits. You can also select different ring tones for phonebook entries.

When storing a name the first character is upper case and the rest lower case.

To change the case manually, press .

To store Pause, press and hold .

To store a Recall, press  (this can only be done for **TIMED BREAK**).

### Store a name and number

If you subscribe to a Caller Display Service and want the name of your caller displayed instead of the number service, enter the full telephone number including the dialling code .

You can store multiple entries with the same name but, to prevent unnecessary duplicates, only store the same number once.

### Entering names

Use the keypad letters to enter names, e.g. to store **TOM**:



Press  once to enter **T**.

Press  three times to enter **O**.

Press  once to enter **M**.

### Writing tips

Press **CLEAR** to delete the last character or digit.

Press  or  to move backwards or forwards through character/digits.

Press  to switch between upper and lower case.

Press **0** to insert a space.

Use **0** or **1** for other punctuation characters.

You must enter a name to go with a number or the entry will not be saved.

### Search alphabetically

Press .

Or

Press NAMES.

SEARCH is highlighted. Press SELECT.  
The list of entries is displayed.







Enter the first letter of the name you want. The first name beginning with that letter is displayed.

Scroll  to view any other entries beginning with that letter.







### Open the phonebook during a call.

1. During your conversation, press NAMES.
2. Use the menu to select ADD ENTRY, SHOW DETAILS, EDIT ENTRY or DELETE ENTRY.





### Edit a name and number

1. Press .
2. Scroll  or  to the entry you want.
3. Press OPTIONS and scroll  to EDIT ENTRY and press SELECT.
4. Press CLEAR to delete characters, use the keypad to enter new ones then press OK.
5. Press CLEAR to delete digits, use the keypad to enter new ones then press SAVE.
6. Scroll  or  to the ringtone you want and press SELECT to save the entry.
7. Press BACK to return to the previous menu level.



### Edit ringtone

1. Press .
2. Scroll  or  to the entry you want.
3. Press OPTIONS and scroll  to RINGTONE and press SELECT.
4. Scroll  or  to the ringtone you want and select OK to save the entry.
5. Press BACK to return to the previous menu level.







### Delete an entry

1. Press .
2. Scroll  or  to the entry you want.
3. Press OPTIONS and scroll  to DELETE ENTRY and press SELECT.
4. Press YES to confirm or NO to cancel.
5. Press BACK to return to the previous menu level.

### Delete entire phonebook



1. Press **NAMES**.
2. Scroll  or  to **DELETE PHONEBOOK** and press **SELECT**.
3. Press **YES** to confirm or **NO** to cancel.
4. Press **BACK** to return to the previous menu level.

### Copy an entry to another handset

1. Press .
2. Scroll  or  to the entry you want.
3. Press **OPTIONS** and scroll  to **COPY ENTRY** and press **SELECT**.
4. **TO HANDSET** is displayed. Press **SELECT**.
5. Available handsets are displayed. Scroll  or  to the handset you want and press **SELECT**. **COPY PHONEBOOK?** is prompted on the receiving handset. Press **YES** to accept or **NO** to cancel. When completed the display shows **1 ENTRY COPIED**.
6. Press **BACK** to return to the previous menu level.

### Copy the entire phonebook to another handset

At the handset you are copying from:

1. Press **NAMES**.
2. Scroll  to **COPY PHONEBOOK** and press **SELECT**.
3. **TO HANDSET** is displayed. Press **SELECT**.
4. Available handsets are displayed. Scroll  or  to the handset you want and press **SELECT**. When completed the display shows the number of entries copied.
5. Press **BACK** to return to the previous menu level.

At the receiving handset:

The display shows **COPY PHONEBOOK?** Press **YES** to begin copying or **NO** to cancel.

If you experience any problems, please call the Helpline on **0800 145 6789\*** or email [bt.helpdesk@sgweurope.com](mailto:bt.helpdesk@sgweurope.com)

When you have more than one handset registered to your BT Synergy 5100 base, you can copy entries between handsets.

In just a few minutes, you can copy all your phonebook contacts to another handset.

#### Memory status

You can check how much of the phonebook memory is available.

1. Press **NAMES**.
2. Scroll  to **MEMORY STATUS** and press **SELECT**.
3. Display shows the number of **USED** and **FREE** entries.
4. Press **BACK** to return to the previous menu level.

**Important**

Make sure your numbers are stored on the SIM card and not just on the mobile itself, otherwise copying will not work.

While SIM copying is taking place do not replace the handset on the base as this will stop the transfer.

However, if an incoming call is received, the copying process is cancelled so that the call can be taken.

The PIN number will be displayed as asterisks for security reasons.

If the memory becomes full during copying from a SIM, the display shows MEMORY FULL NOT ALL COPIED.



Most SIM cards are supported, but if the SIM Card format is not compatible, the display shows SIM FORMAT NOT SUPPORTED.

When copying from a SIM only the first 12 characters of each name are copied and the first 24 digits in a number are copied.



If an entry with a duplicate number is found, the entry will not be copied.

PLEASE INSERT SIM CARD will be displayed if you have not already inserted a SIM card into the base.



**Copy an entry to a SIM card**

1. Insert the SIM card into the SIM READER slot on the side of the base.
2. Press  to open the phonebook list then press OPTIONS.
3. Scroll  to COPY ENTRY and press SELECT.
4. Scroll  to TO SIM and press SELECT.
5. If requested, enter your SIM PIN then press OK.
6. Display shows PLEASE WAIT . . . % as it copies entries from the SIM. When completed the display shows <NAME> COPIED.
7. Press BACK to return to the previous menu level.

**Copy all entries to or from a SIM card**

1. Insert the SIM card into the SIM READER slot on the side of the base.
2. Press NAMES.
3. Scroll  to COPY PHONEBOOK and press SELECT.
4. Scroll  to either FROM SIM or TO SIM and press SELECT.
5. If requested, enter your SIM PIN then press OK.
6. Display shows COPYING and the name of each entry. When completed the display shows the number of entries.
7. Press BACK to return to the previous menu level.

### Change the dialling code

1. Press **NAMES**.
2. Scroll  to **DIALLING CODES** and press **SELECT**.
3. Scroll  to the part of the dialling code you need to change, **INTERNATIONAL**, **COUNTRY** or **LOCAL** and press **SELECT**.
4. Enter the new code and press **SAVE**.
5. Press **BACK** to return to the previous menu level.

### Local code

The Dialling Codes function automatically converts SIM entries beginning with international dialling codes to the local code. For example, on a SIM card, + is the international code and 44 is the country code. These will be replaced automatically by the local code 0 so that a number beginning +44207 will be converted to 0207.

You should not normally need to alter this setting if you are using your BT Synergy in the UK and your mobile to call UK numbers. If this is not the case, then please call the BT Synergy Helpline for assistance on 0800 145 6789\*.

# Handset settings

You can set different ringtones for external calls and internal calls.

Select from 20 handset ringtones.

You will hear a sample ring for each one you highlight (if the ringer is not switched off).





The handset has 5 ringer volume settings plus Off.

If the volume is set to Off the  icon is displayed.





The default setting is level 5.

This sets the standard volume level for the handset earpiece. There are 8 levels to choose from.





## Handset ringtone

1. Press MENU, scroll  to SETTINGS and press SELECT.
2. SET HANDSET is highlighted. Press SELECT.
3. RINGTONE is highlighted. Press SELECT.
4. Press  or  to highlight EXTERNAL CALL or INTERNAL CALLS. Press SELECT to confirm.
5. Scroll  or  to highlight the ringtone you want.
6. Press SELECT to confirm.
7. Press BACK to return to the previous menu level.



## Handset ringer volume

1. Press MENU, scroll  to SETTINGS and press SELECT.
2. SET HANDSET is highlighted. Press SELECT.
3. Scroll  to RINGER VOLUME and press SELECT.
4. Press  or  to display the volume level you want. Press SELECT to confirm.
5. Press BACK to return to the previous menu level.





## Receiver volume

1. Press MENU, scroll  to SETTINGS and press SELECT.
2. SET HANDSET is highlighted. Press SELECT.
3. Scroll  to RECEIVER VOLUME and press SELECT.
4. Press  or  to display the volume level you want. Press SELECT to confirm.
5. Press BACK to return to the previous menu level.





### Handset name

1. Press MENU, scroll  to SETTINGS and press SELECT.
2. SET HANDSET is highlighted. Press SELECT.
3. Scroll  to HANDSET NAME and press SELECT.
4. Use the keypad to enter the name and press SAVE.
5. Press BACK to return to the previous menu level.

### Display language

1. Press MENU, scroll  to SETTINGS and press SELECT.
2. SET HANDSET is highlighted. Press SELECT.
3. Scroll  to LANGUAGE and press SELECT.
4. Scroll  or  to the language you want and press SELECT.
5. Press BACK to return to the previous menu level.

### Light timeout

1. Press MENU, scroll  to SETTINGS and press SELECT.
2. SET HANDSET is highlighted. Press SELECT.
3. Scroll  to LIGHT TIMEOUT and press SELECT.
4. Scroll  or  to set the timeout period you want then press SELECT.
5. Press BACK to return to the previous menu level.





If you are using more than one handset with your BT Synergy 5100 base, you can give each handset a personalised name to easily distinguish between the handsets.

A name can be up to 10 characters long.





The available languages include: English, Francais, Deutsch, Italiano and Espanol.

Set how long the backlight stays on after the last button press.





### Auto talk

1. Press MENU, scroll  to SETTINGS and press SELECT.
2. SET HANDSET is highlighted. Press SELECT.
3. Scroll  to AUTO TALK and press SELECT.
4. Scroll  or  to ON or OFF then press SELECT.
5. Press BACK to return to the previous menu level.

### Key beep

1. Press MENU, scroll  to SETTINGS and press SELECT.
2. SET HANDSET is highlighted. Press SELECT.
3. Scroll  to KEY BEEP and press SELECT.
4. Scroll  or  to OFF or ON then press SELECT.
5. Press BACK to return to the previous menu level.

### PABX access code





1. Press MENU, scroll  to SETTINGS and press SELECT.
2. SET HANDSET is highlighted. Press SELECT.
3. Scroll  to PABX ACCESS CODE and press SELECT.
4. Scroll  or  to ON, OFF or SET CODE then press SELECT.

If you select SET CODE, enter the switchboard access code e.g. 9 then press SAVE.





5. Press BACK to return to the previous menu level.

# Base settings





## Base ringtone

1. Press **MENU**, scroll  to **SETTINGS** and press **SELECT**.
2. Scroll  to **SET BASE** and press **SELECT**.
3. **RINGTONE** is highlighted. Press **SELECT**.
4. Scroll  or  to highlight the ringtone you want.
5. Press **SELECT** to confirm.
6. Press **BACK** to return to the previous menu level.

## Base ringer volume

1. Press **MENU**, scroll  to **SETTINGS** and press **SELECT**.
2. Scroll  to **SET BASE** and press **SELECT**.
3. Scroll  to **RINGER VOLUME** and press **SELECT**.
4. Press  or  to display the volume level you want.  
Press **SELECT** to confirm.
5. Press **BACK** to return to the previous menu level.

## Dialling mode

1. Press **MENU**, scroll  to **SETTINGS** and press **SELECT**.
2. Scroll  to **SET BASE** and press **SELECT**.
3. Scroll  to **DIALLING MODE** and press **SELECT**.
4. Press  or  to highlight **PULSE** or **TONE** then press **SELECT** to confirm.
5. Press **BACK** to return to the previous menu level.

Select from 5 base ringtones.

You will hear a sample ring for each one you highlight (if the ringer is not switched off).

The base has 5 ringer volume settings plus Off. The default setting is level 5.





Your BT Synergy 5100 is pre-set to Tone dialling. You should not normally need to change this setting. The dial mode options are Tone (Time Break/Earth) or Pulse (Earth).



When you have more than one handset registered to your base, you can set one handset to ring before the other handsets. This allows one handset user to answer all incoming first, like a receptionist.



Choose ALL HANDSETS if you want all handsets to ring at the same time or SELECT HANDSET to nominate a handset to ring two times before the others.

The default setting is ALL HANDSETS.

### Ring priority





1. Press MENU, scroll  to SETTINGS and press SELECT.
2. Scroll  to SET BASE and press SELECT.
3. Scroll  to RING PRIORITY and press SELECT.
4. Press  or  to highlight ALL HANDSETS or SELECT HANDSET then press SELECT.

If you choose SELECT HANDSET all available handsets are displayed. Scroll  or  to highlight the handset you want then press SELECT.





Scroll  or  to the number of rings you want to set 2, 4 or 6 and press SELECT.

5. Press BACK to return to the previous menu level.



### Recall mode

1. Press MENU, scroll to SETTINGS and press SELECT.
2. Scroll  to SET BASE and press SELECT.
3. Scroll  to RECALL MODE and press SELECT.
4. Press  or  to highlight TIMED BREAK or EARTH then press SELECT to confirm.
5. Press BACK to return to the previous menu level.



### First ring

1. Press MENU, scroll  to SETTINGS and press SELECT.
2. Scroll  to SET BASE and press SELECT.
3. Scroll  to FIRST RING and press SELECT.
4. Press  or  to ON or OFF then press SELECT to confirm.
5. Press BACK to return to the previous menu level.

### System PIN

1. Press MENU, scroll  to SETTINGS and press SELECT.
2. Scroll  to SET BASE and press SELECT.
3. Scroll  to SYSTEM PIN and press SELECT.
4. Enter the old PIN (original setting 0000) and press OK.
5. Enter the new PIN and press OK.
6. Re-enter the new PIN and press OK.
7. Press BACK to return to the previous menu level.

### Restore default settings

1. Press MENU, scroll  to SETTINGS and press SELECT.
2. Scroll  to SET BASE and press SELECT.
3. Scroll  to MASTER RESET and press SELECT.
4. Select YES to confirm or NO to cancel.
5. Enter the system PIN (original setting 0000) then press OK. The display will show RESET COMPLETE then return to standby.

If you have subscribed to your network's Caller Display service, your BT Synergy 5100 does not ring until the caller information has been received and displayed.

However, if you want your handset to ring without waiting for the caller information to be displayed, set First Ring to On. Please note that this will mean the first ring you hear will be the default ringtone. This will change to any ringtone you have set once the caller information is displayed.

The System PIN is used when changing certain settings and registration / de-registration. The default setting is 0000. You can change this to your own preferred number up to 8 digits.

When you enter a PIN the digits are shown as \*\*\*\*\*.

You can restore your BT Synergy 5100 to its default (original) settings.

It will not affect the phonebook, calls list or user's data.

All handsets registered to the base will be retained.

All text, handset and base settings will be reset.

You can set the time to either 12 or 24 hour format, see page 29.

When the alarm is set, the display shows the  icon.

Each handset can have a different alarm setting.

Once an alarm has been set, you can switch the setting on or off.

If the alarm was set to ONCE the  will disappear from the screen.

If set to ON DAILY or MON-FRI the  will remain on the screen.







If you are using the handset to make a call when the alarm ring is due, the  flashes and you hear a beep in the earpiece.

## Date & time





If you subscribe to your network's caller display service, the base sets the date and time for all handsets whenever a call is received. You can manually set the time on an individual handset.

1. Press MENU, scroll  to CLOCK & ALARM and press SELECT.
2. DATE & TIME is highlighted, press SELECT.
3. Enter the date using the format DD/MM/YY and press SAVE.
4. Enter the time and press SAVE.
5. Press BACK to return to the previous menu level.

## Set alarm





1. Press MENU, scroll  to CLOCK & ALARM and press SELECT.
2. Scroll  to ALARM and press SELECT.
3. Press  or  to select ON and press SELECT.
4. Press  or  to select ONCE, MON-FRI or ON DAILY and press SELECT.
5. Enter the time you want the alarm and press SAVE.
6. Press BACK to return to the previous menu level.

## Alarm on /off

1. Press MENU, scroll  to CLOCK & ALARM and press SELECT.
2. Scroll  to ALARM and press SELECT.
3. Press  or  to select ON or OFF and press SELECT.
4. Press BACK to return to the previous menu level.

### Time format

Set the time format to 12 or 24 hour setting.

1. Press MENU, scroll  to CLOCK & ALARM and press SELECT.
2. Scroll  to TIME FORMAT and press SELECT.
3. Press  or  to select 12 HOUR or 24 HOUR and press SELECT.
4. Press BACK to return to the previous menu level.

### Switch off alarm ring

1. When the alarm goes off, press STOP.

Set the time format to 12 or 24 hour setting.

# Agenda





Use your BT Synergy 5100 to remind you of details of up to five events such as birthdays, anniversaries or appointments. The entry can be up to 24 characters long.

Up to 24 characters can be entered as the subject.



If you select a silent reminder, the event subject is displayed on screen but no alarm will sound.



When the event memory is full, the display shows MEMORY FULL. You must delete an event before you can add a new one.

## Add a new event

1. Press MENU, scroll  to AGENDA and press SELECT.
2. If no previous event is stored, ADD EVENT is highlighted press SELECT.  
Or  
If events are already stored, they are listed. Press OPTIONS. ADD EVENT is highlighted. Press SELECT.
3. Enter the subject and press SAVE.
4. Enter the date (DD/MM) and press SAVE.
5. Enter the time (HH:MM) and press SAVE. If the current time format setting is 12 hour, select am or pm by pressing  or .
6. Press  or  to select SILENT or ALARM and press SELECT.

If you press ALARM:

Scroll  or  to select ONCE or ANNUALLY and press SELECT.

Scroll  or  to select when you want to receive the reminder AT EVENT TIME or 30 MIN BEFORE, press SELECT.



Display shows SAVED.

7. Press BACK to return to the previous menu level.





## Switch off agenda ring

1. The event is displayed. Press VIEW to stop the alarm and see the details of the event. Or press BACK to stop the alarm and return to the standby screen. If no button is pressed, the alarm stops after one minute.



### Show agenda details



1. Press MENU, scroll  to AGENDA and press SELECT.
2. Stored events are displayed. If required, scroll  to the event you want and press OPTIONS.
3. Scroll  to SHOW DETAILS and press SELECT. The description, date and time of the reminder are displayed.
4. Press BACK to return to the previous menu level.

### Edit agenda

1. Press MENU, scroll  to AGENDA and press SELECT.
2. Stored events are displayed. If required, scroll  to the event you want and press OPTIONS.
3. Scroll  to EDIT EVENT and press SELECT.
4. Edit the subject and press SAVE.
5. Edit the date and time then press SAVE.
6. Press  or  to select SILENT or ALARM and press SELECT.

If you press ALARM:



Scroll  or  to select ONCE or ANNUALLY and press SELECT.

Scroll  or  to select when you want to receive the reminder AT EVENT TIME or 30 MIN BEFORE, press SELECT.



Display shows SAVED.

7. Press BACK to return to the previous menu level.



### Send agenda as a text message

1. Press MENU, scroll  to AGENDA and press SELECT.
2. Stored events are displayed. Scroll  to the event you want and press OPTIONS.
3. Scroll  to SEND AS A TEXT and press SELECT.
4. The event is displayed. Press OPTIONS to select SEND option and enter a destination number.

### Delete agenda

1. Press MENU, scroll  to AGENDA and press SELECT.
2. Stored events are displayed. Scroll  to the event you want and press OPTIONS.
3. Scroll  to DELETE EVENT and press SELECT.
4. Press YES to confirm or NO to cancel.
5. Press BACK to return to the previous menu level.

### Delete all agendas

1. Press MENU, scroll  to AGENDA and press SELECT.
2. Stored events are displayed. Press OPTIONS.
3. Scroll  to DELETE ALL EVENTS and press SELECT.
4. Press YES to confirm or NO to cancel.
5. Press BACK to return to the previous menu level.

## Caller Display

If you have subscribed to a Caller Display Service, you will be able to see your caller's number on your handset display (provided it is not withheld) prior to answering the call.

If your caller's name and number are stored in the phonebook and a name/number match is found, you will see the caller's name on the display instead.

## Calls lists



Each handset can hold details of up to 30 answered or unanswered calls and 20 dialled calls.

The caller's details are stored in a Calls list whether you answered the call or not. When the list is full, and a new call is received, the oldest entry will be deleted automatically.

## New calls alert

When you have missed calls, the standby display shows YOU HAVE X NEW MISSED CALLS. If you press BACK, the message disappears and is replaced with the  icon and the number of missed calls is displayed underneath.

## View new missed calls

1. When you see the new calls alert, press VIEW. You can now scroll  or  through the MISSED CALLS LIST.
2. Press OPTIONS. SHOW DETAILS is highlighted. Press SELECT to see the details.
3. Press BACK to return to the previous menu level.

### IMPORTANT

To use Caller Display you must first subscribe to the service from your network provider. A quarterly fee may be payable. For more information on BT Calling Features call BT free on 0800 800 150.

To ensure the caller's name is displayed, make sure you have stored the full telephone number, including the dialling code in the phonebook.

If the caller's number is stored in the phonebook, the name assigned to it is displayed.



If the number is unavailable, UNAVAILABLE will be displayed.

If the call is from an international number, INTERNATIONAL will be displayed.



If the call is from the operator, OPERATOR will be displayed.

If the call is from a payphone, PAYPHONE will be displayed.

If the call is from a ringback request, RINGBACK will be displayed.

Use the  and  buttons to toggle between showing the number or the number plus the time and date.

New calls in the calls list have a large dot next to them to indicate that they haven't been viewed yet.





Use the  and  buttons to toggle between showing the number or the number plus the time and date.

See 'Entering names' and 'Writing tips' on page 17.









If you need to edit the number, use CLEAR to delete any unwanted digits, then enter new ones using the keypad.

See page 40 for more information on text messaging.





### View and dial from a Calls list

1. Press MENU, scroll  to CALLS LISTS and press SELECT. MISSED CALLS is highlighted. Scroll  or  to choose MISSED CALLS, RECEIVED CALLS or DIALLED CALLS.
2. Press SELECT. You can now scroll  or  through the list.
3. Press OPTIONS. SHOW DETAILS is highlighted.
4. Press SELECT to see the caller's details.
5. Press DIAL to call the number.
6. Press BACK to return to the previous menu level.

### Copy a Calls list number to the phonebook







1. Press MENU, scroll  to CALLS LISTS then press SELECT. MISSED CALLS is highlighted.  
If required, scroll  or  to RECEIVED or DIALLED CALLS then press SELECT.
2. Scroll  or  to the entry you want and press OPTIONS.
3. Scroll  to SAVE NUMBER. Press SELECT.
4. Enter a name then press OK. The number is displayed, press SAVE.
5. Scroll  or  to the ringtone you want and press SELECT.
6. Press BACK to return to the previous menu level.

### Send a text message to a Calls list number





1. Press MENU, scroll  to CALLS LISTS then press SELECT. MISSED CALLS is highlighted. If required, scroll  or  to RECEIVED or DIALLED CALLS then press SELECT.
2. Scroll  or  to the entry you want and press OPTIONS.

3. Scroll  to SEND MESSAGE. Press SELECT.
4. Write the message then press OPTIONS.
5. SEND is highlighted. Then press SELECT. (You can save, insert a symbol, emoticon or template).
6. The number is pre-entered on the Send to screen, press SEND to send the message.
7. Press BACK to return to the previous menu level.

#### Delete an entry

1. Press MENU, scroll  to CALLS LISTS then press SELECT. MISSED CALLS is highlighted. If required, scroll  or  to RECEIVED or DIALLED CALLS then press SELECT.
2. Scroll  or  to the entry you want and press OPTIONS.
3. Scroll  to DELETE CALL. Press SELECT.
4. Press BACK to return to the previous menu level.

#### Delete all entries

1. Press MENU, scroll  to CALLS LIST then press SELECT. MISSED CALLS is highlighted. If required, scroll  or  to DELETE CALLS press SELECT.
2. Scroll  or  to highlight MISSED CALLS, RECEIVED CALLS, DIALLED CALLS or ALL CALLS. Press SELECT.
3. Press YES to confirm or NO to cancel.
4. Press BACK to return to the previous menu level.



You can delete all entries in an individual Calls list or all entries from all Calls lists.

# Call Waiting

You must subscribe to your network's Caller Display service for Call Waiting to work. A quarterly fee may be payable.

See page 38 for instructions on how to switch your Call Waiting service on or off.

## Call Waiting

1. During a call, you hear a soft beep in the earpiece and the display shows the number of the caller or the name if it matches an entry in your phonebook. If these are not available, the display shows **CALL WAITING**.
2. Press  to put your current caller on hold and speak to the new caller.
3. Press  again to switch between both callers.
4. Press  to finish the current call.

By selecting the BT Services menu you can access a range of useful pre-stored numbers and further BT Calling Features.

Up to 22 entries are available in the Useful Numbers directory. The spare entries can be handy for storing important services such as the number of your Doctor or Dentist.



## Pre-stored BT Services numbers:

- BT HELPLINE
- BT 118500
- DIVERT ON
- DIVERT OFF
- DIVERT CHECK
- C WAIT ON
- C WAIT OFF
- C WAIT CHECK

### BT Helpline

1. Press MENU then scroll  to NETWORK SERVICES and press SELECT.
2. BT HELPLINE is highlighted. Press OPTIONS.
3. SHOW DETAILS is highlighted. Press SELECT.
4. Press DIAL to call.

### BT 118500 (Directory Enquiries)

1. Press MENU then scroll  to NETWORK SERVICES and press SELECT.
2. Scroll  to BT 118500. Press OPTIONS.
3. SHOW DETAILS is highlighted. Press SELECT.
4. Press DIAL to call.

### IMPORTANT

To use BT Services and BT Calling Features you must first subscribe (if required) to the relevant service from your network provider. A quarterly fee may be payable.

#### Please note

Some of these services are chargeable e.g. BT 118 500 and Call Divert.

For more details on BT's Calling Features, call BT free on 0800 800 150.

If you are not connected to the BT network, some of these services may not be available. Please contact your network provider. Call Diversion services may allow other divert options. Check with your network provider for details.

For further information, see the BT Calling Features user guide supplied when you subscribe to the services of your choice.

If you use this feature you will pay for the cost of the diverted call.

Call Waiting lets you know if another person is trying to contact you while you are on a call. If a second caller rings you will hear a beep in the handset. Providing you have also subscribed to Caller Display, the screen will show the caller's details.



See page 36 for instructions on how to use Call Waiting.

You can edit existing entries or use an 'empty' slot to enter your own preferred number in the Useful Numbers directory.



Names can be up to 12 characters and number up to 24 digits long.

### Call Divert on/off/check



Call Divert will divert all incoming calls to another number of your choice.

1. Press MENU then scroll  to NETWORK SERVICES and press SELECT.
2. Scroll  to DIVERT ON, DIVERT OFF or DIVERT CHECK. Press OPTIONS.
3. SHOW DETAILS is highlighted. Press SELECT.
4. Press DIAL to call. Follow the spoken instruction, or listen for confirmation/status of your instructions.



### Call Waiting on/off/check

1. Press MENU then scroll  to NETWORK SERVICES and press SELECT.
2. Scroll  to C WAIT ON, C WAIT OFF or C WAIT CHECK. Press OPTIONS.
3. SHOW DETAILS is highlighted. Press SELECT.
4. Press DIAL to call. Listen for confirmation of your instruction or hear the status of your CALL WAITING.



### Add or edit an entry

1. Press MENU then scroll  to NETWORK SERVICES and press SELECT.
2. Scroll  to the entry you want. Press OPTIONS.
3. Scroll  to EDIT ENTRY. Press SELECT.
4. Enter the name you want and press SAVE.
5. Enter the number you want and press SAVE.
6. Press BACK to return to the previous menu level.



### Dial a stored entry

1. Press MENU then scroll  to NETWORK SERVICES and press SELECT.
2. Scroll  to the entry you want and press OPTIONS.
3. SHOW DETAILS is highlighted. Press SELECT.
4. Press DIAL to dial the number.
5. Press BACK to return to the previous menu level.

### Delete an entry

1. Press MENU then scroll  to NETWORK SERVICES and press SELECT.
2. Scroll  to the entry you want and press OPTIONS.
3. Scroll  to DELETE ENTRY and press SELECT.
4. Press YES to confirm or NO to cancel.
5. Press BACK to return to the previous menu level.

### Delete all entries

1. Press MENU then scroll  to NETWORK SERVICES and press SELECT.
2. Press OPTIONS.
3. Scroll  to DELETE ALL and press SELECT.
4. Press YES to confirm or NO to cancel.
5. Press BACK to return to the previous menu level.

# Text messaging

## IMPORTANT

You must subscribe to your Network Provider's Caller Display service so that you can use text messaging and you must not withhold your telephone number.



A quarterly fee may be payable, please contact your network provider for more details.

Some other network provider lines may not be compatible with this text messaging service.

You may also send messages to landline phones that are NOT text compatible. Messages to non-compatible lines will be connected to voice text and delivered in spoken words to the telephone as a call. Please note that the conversion can translate common abbreviations and smileys etc, but to ensure maximum clarity of message delivery, abbreviations etc should be used sparingly.

## Writing tips

Press CLEAR to delete incorrect characters.

Use  or  to move the cursor through the text, if you want to insert/delete text.

## Upper & lower case

Press  to switch between upper case ABC, lower case abc letters and numbers.

Maximum number of characters in a text message is 160. The display shows a character countdown from 160 down to 0 (Unless message size is set to 612 characters).

If the text is unsuccessful, the message UNABLE TO SEND will be displayed.

In order to send and receive text messages you must not withhold your number. On most networks if you normally withhold your number the 1470 prefix presents your number for you.

Welcome to the BT text messaging service on your BT Synergy. Your BT Synergy 5100 can send and receive text messages from participating mobile networks and compatible landline telephones in the UK.

The fixed line text service is provided under BT's terms and conditions for telephone service. These can be found by visiting the BT.com website at: <http://www.bt.com/terms>

## Subscribe to the text messaging service

When you send your first text message from your BT Synergy 5100 you will automatically be registered for the service.

On receipt of your first text through the service, the system will send you a welcome text message back. You may also register by sending the word 'Register' to 00000 upon which you will receive a confirmation message.

## Cost of the fixed line service

There is no subscription charge (other than the subscription to Caller Display). Visit the BT.com website ([www.bt.com](http://www.bt.com)) to find out how much it costs to send a text message (depends upon your call package).

## Send a text message

1. Press MENU, TEXT MESSAGING is displayed, press SELECT.
2. WRITE MESSAGE is highlighted. Press SELECT.
3. Use the keypad to enter your message.
4. Press OPTIONS.

SEND is highlighted



Press SELECT to send the message.  
Enter the phone number or press  
Search to open the phonebook  
then scroll to the number you want  
and press SELECT. Now press SEND.

Or scroll  or  to:



SAVE

Press SELECT to save the message in  
the Drafts folder.



INSERT SYMBOL

Press SELECT. The symbol table is displayed.  
Press  or  to highlight the symbol you  
want then press INSERT.

INSERT EMOTICON

Press SELECT. The Emoticon table is displayed.  
Press  or  to highlight the Emoticon  
you want then press Insert.

INSERT TEMPLATE

Press SELECT. The list of templates is displayed.  
Press  or  to highlight the Template you  
want then press INSERT.

4. When sending a message, the display shows SENDING MESSAGE then MESSAGE SENT.

### Standard text entry

With standard text entry you can enter a word by pressing each letter button a number of times to display the character you want on the screen. For example, to write the word "Hello", press **4<sup>th</sup>** twice, **3<sup>rd</sup>** twice, **5<sup>th</sup>** three times, **5<sup>th</sup>** three times and **6<sup>th</sup>** three times.

### Receiving and reading text messages

When you receive a new text message, the  icon is displayed along with YOU HAVE X NEW MESSAGES.

#### Symbols

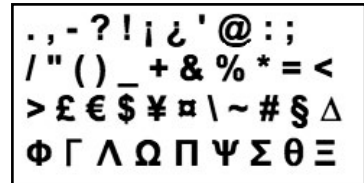

#### Emoticons



#### Do you have two text phone bases connected to the same phone line?

If you have two text phone base stations plugged into one line, you are likely to experience problems receiving text messages. Normally, only one SMS enabled base unit (DECT or cordless) can be plugged into any line.

If you do want to use two base units and still receive written text you must delete receive service centre number from one of the base stations. To do this on your BT Synergy 5100, see page 45. This will allow you to send text via either base station but texts will only be received on the product with the active receive centre number.

If the base unit with the active receive centre number is a DECT product then all handsets registered to it will be able to receive text messages.

#### Total number of messages

Your BT Synergy 5100 can store up to a total of 50 short messages across all handset Outboxes, Drafts boxes and Inboxes.

#### Memory full alert

If the text mailboxes are full when you attempt to write a new message the display shows MEMORY FULL DELETE MESSAGES for 2 seconds. You must delete messages before you can write and send a new one.

**Templates**

There are three pre-set templates

Please call

I'll be there at

What time will you be home?

You can edit the templates, up to a maximum of 32 characters.

**Receiving a call while writing a text**

If you are writing a text and you receive a call the text will be lost.

**Sent texts are stored in the Outbox**



Your BT Synergy's outbox is like a redial list. It holds a copies of up to 5 sent messages. When the Outbox is full, a new message replace the oldest.

**Saved messages are stored in the Drafts box**

If you save a message to complete or send later it will be stored in the Drafts box. Only one message can be saved in each user's Drafts box.











Received messages are stored in the Inbox.

**Read a new message**

1. The Inbox is opened and the list of messages displayed. If you press **BACK** the message is stored in the Inbox for reading later.
2. In the Inbox scroll  (to more recent messages) or  (to earlier list of messages) through the list of messages.
3. Highlight the message you want to read and press **READ** or press **BACK** to return to Text messaging menu.
4. Press  to return to standby.

**Read, forward, delete, view and save numbers of texts in the Inbox**

When you see the new message alert, if you press **BACK** the message is stored in your Inbox so you can read it later.

1. Press **MENU**, **TEXT MESSAGING** is displayed. If you have new messages you will go straight to the Inbox, if not scroll  to Inbox and press **SELECT**.
2. Scroll   or  to the message you want and press **READ**. Scroll   or  through the message.
3. Press **OPTIONS** and scroll   or  to:

**REPLY**



Press **SELECT**. Write your reply then press **OPTIONS** and select **SEND**.

**FORWARD**

Press **SELECT**. The message is displayed. Press **OPTIONS**. Display highlights **SEND**. Press **SELECT** and enter a number or search for the number then press **SEND**.



**MESSAGE DETAILS**

You can see who sent the message and then call them. Press **SELECT** the sender's number is displayed. Press **DIAL** if you want to call the number.

**USE NUMBER** To call the sender, press **SELECT**. The display shows **CALL**. Press **SELECT** to call the sender OR to save the number, scroll  to **SAVE** and press **SELECT**. Enter a name and press **OK**, edit the number if required then press **SAVE**. Scroll  or  to the ringtone and press **SELECT**. The number is saved in the phonebook.



**DELETE** Press **SELECT**. Press **YES** to confirm or **NO** to cancel.



### Edit or send texts in the Drafts box



1. To open the Drafts box, press **MENU**, **TEXT MESSAGING** is displayed. Press **SELECT**.
2. Scroll  to **DRAFTS** and press **SELECT**.
3. Press **EDIT** to edit your message content.
4. Press **OPTIONS** and scroll  or  to:

**SEND** Press **SELECT** to send the message. Enter the phone number or press **SEARCH** to open the phonebook then scroll to the number you want and press **SELECT**. Press **SEND**.

**SAVE** Press **SELECT** to save the message in the Drafts folder.

**INSERT SYMBOL** Press **SELECT**. The symbol table is displayed. Press  or  to highlight the symbol you want then press **INSERT**.

**INSERT EMOTICON** Press **SELECT**. The Emoticon table is displayed. Press  or  to highlight the Emoticon you want then press **Insert**.

**INSERT TEMPLATE** Press **SELECT**. The templates list is displayed. Press  or  to highlight the Template you want then press **INSERT**.

5. When sending a message, the display shows **SENDING MESSAGE** then **MESSAGE SENT**.

### Edit templates

There are three pre-set templates

Please call

I'll be there at

What time will you be home?





You can change the templates to your preferred message, up to a maximum of 32 characters.



If you delete a template without replacing the text it is marked as Empty.

All templates are restored if you reset your BT Synergy 5100 to its default settings, see page 27.

### Forward or delete texts in the Outbox

1. To open the Outbox box, press MENU, TEXT MESSAGING is displayed. Press SELECT. Scroll  to OUTBOX and press SELECT.

2. Scroll  or  to the message you want and press READ. Scroll  or  through the message.

3. Press OPTIONS and scroll  or  to:

FORWARD

Press SELECT. The message is displayed.

Press OPTIONS. Display highlights SEND.

Press SELECT and enter the number or press SEARCH to search the phonebook. When the number is entered, press SEND.

DELETE

Press SELECT then press YES to confirm or NO to cancel.

4. Press  to return to standby.

### Edit templates

1. Press MENU, TEXT MESSAGING is displayed. Press SELECT scroll  to TEMPLATES and press SELECT.

2. Scroll  or  to the template you want and press OPTIONS.

EDIT

Press SELECT. Press CLEAR to delete characters.



Enter your template text and press SAVE.

DELETE

Press SELECT. Press YES to confirm or NO to cancel.

3. Press  to return to standby.

### Deleting texts

1. Press **MENU**, **TEXT MESSAGING** is displayed. Press **SELECT** scroll  to **DELETE MESSAGES** and press **SELECT**.
2. Scroll  or  to **INBOX**, **DRAFTS**, **OUTBOX** or **ALL MESSAGES** and press **SELECT**.
3. Press **YES** to confirm or **NO** to cancel.
4. Press **BACK** to return to standby.







### Service Centre numbers

To send and receive text messages you need the telephone number of your Network's text Centre. If you accidentally delete the Outgoing or Incoming Service Centre numbers you will need to re-enter them in order for your text Service to work. You can enter up to 4 Service Centre numbers – two incoming and two outgoing.

The Send Centre number is: 1470P1709400.

The Receive Centre is: 080058752.

### Add or change Service Centre numbers

1. Press **MENU**, **TEXT MESSAGING** is displayed. Press **SELECT**, scroll  or  to **TEXT SETTINGS** and press **SELECT**.
2. **SERVICE CENTRES** is highlighted press **SELECT**.
3. Scroll  or  to **RECEIVE CENTRES** or **SEND CENTRE** and press **SELECT**.
4. Scroll  or  to **CENTRE 1** or **CENTRE 2** and press **SELECT**.
5. Enter the number for the centre and press **SAVE**.
6. Press **BACK** to return to the previous menu level.





Selecting **ALL MESSAGES** will delete all messages stored in your Inbox, Outbox and Drafts box.

If you have more than one 'Server Centre' stored on your BT Synergy 5100 you will need to select which one you want to use for sending (see next section).





When you receive a text message, the message alert tone will sound. These beeps can be switched on or off.

A standard text message is 160 characters long. You can set a message to be up to 612 characters and the message will be sent as up to 4 linked messages each up to 160 characters long





### Set send centre

1. Press MENU, TEXT MESSAGING is displayed. Press SELECT. Scroll  or  to TEXT SETTINGS and press SELECT.
2. SERVICE CENTRES is highlighted press SELECT.
3. Press SELECT again to choose SET SEND CENTRE.
4. Scroll  or  to RECEIVE CENTRE 1 or RECEIVE CENTRE 2 or SEND CENTRE 1 or SEND CENTRE 2 and press SELECT.
5. Press BACK to return to the previous menu level.

### Message alert tone

1. Press MENU, TEXT MESSAGING is displayed. Press SELECT. Scroll  to TEXT SETTINGS and press SELECT.
2. Scroll  to MESSAGE ALERT and press SELECT.
3. Scroll  or  to ON or OFF and press SELECT.
4. Press BACK to return to the previous menu level.

### Set message size

1. Press MENU, TEXT MESSAGING is displayed. Press SELECT. Scroll  to TEXT SETTINGS and press SELECT.
2. Scroll  to MESSAGE SIZE and press SELECT.
3. Scroll  or  to highlight 160 or 612 characters, then press SELECT.
4. Press BACK to return to the previous menu level.

You can use up to five BT Synergy additional handsets with your BT Synergy 5100 base to extend your phone system without needing to install extension sockets for each new phone.

Your BT Synergy 5100 handset can also be registered to up to 3 other bases. You can then select the base you would prefer to use.

If you have purchased a BT Synergy 5100 multiple pack any additional handsets come pre-registered to the base.

If you have purchased an additional handset separately you must register it to your BT Synergy 5100 base before it can be used.

## Registering an additional handset

At the base:



1. Press and hold  for 3 seconds until the base Power / In use starts flashing. You have up to 60 seconds to register the handset.

At the handset:

1. If the handset is new and the display shows PLEASE REGISTER. Press MENU. The display shows REGISTRATION. Press SELECT.

Or

If the handset has already been registered to another base the standby display is shown. Press MENU, scroll  or  to REGISTRATION and press SELECT.

2. REGISTER HANDSET is highlighted. Press SELECT.
3. Bases are displayed. If necessary, scroll  or  to a new base you wish to register your BT Synergy 5100 handset to and press SELECT.
4. Enter the system PIN and press OK.
5. The display shows SEARCHING BASE X (where X is the chosen base number) then HANDSET REGISTERED.

The handset is automatically assigned the next available handset number.

Default PIN code = 0000

If registration is not successful first time, please repeat the process again incase the base registration period ran out of time.





If there are already 5 handsets registered to the base, the registration will fail. You must de-register another handset before you can register the new one.

Use one handset to de-register another. You cannot de-register the handset you are using.





Default PIN code = 0000

### Select a base

If your BT Synergy 5100 handset is registered to more than one base, you can select which base to use.

1. Press MENU, scroll  or  to REGISTRATION and press SELECT.
2. Scroll  to SELECT BASE and press SELECT.
3. All base numbers are displayed. (In use) is added to bases where the handset was previously registered to. Scroll  or  to the base you want and press SELECT.
4. Display shows SEARCHING BASE... then the standby display for that base.

### De-register a handset

1. Press MENU, scroll  or  to REGISTRATION and press SELECT.
2. Scroll  to DE-REGISTER and press SELECT.
3. Enter the system PIN and press OK.
4. Scroll  or  to the handset you want to de-register and press SELECT.
5. Press YES to confirm or NO to cancel. The display confirms de-registration.
6. Press BACK to return to the previous menu level or close the handset cover to return to standby.

## Internal calls

### Call another handset

If you have more than one handset registered to the base, you can make internal calls between two handsets.

1. Press **Intercom** then the number (1-5) of the handset you want to call.
2. Press **OK** to dial.

### Transfer a call

You can transfer an external call to another handset registered to the base.

During your call:

1. Press **Intercom** then the handset number (1-5) you want.
2. Press **OK** to dial or press **END** to cancel the calls request and return to the caller.
3. When the other handset answers you can announce the caller.
4. Press **↔** to complete the transfer or **Intercom** to switch back and forth between both callers.

### 3-Way conference call

You can hold a 3-way conference call between 2 internal callers and 1 external caller.

During a call to an external caller:

1. Press **Intercom** then the handset number (1-5) you want.
2. Press **OK** to dial.
3. When the other handset answers you can announce the caller.
4. Press **JOIN** to begin the conference call. Display shows **CONFERENCE CALL**.
5. Press **↔** to hang up.

### Handset external display

When an internal call is received, the display shows Internal Call Handset X (where X is the calling handset) and the handset number.

If the other handset does not answer, press **END** to return to your original caller.

## **Phone does not work**

- Have you installed the batteries correctly?
- Check that the mains power is correctly connected.

## **No dial tone**

- Is the telephone cord of the base plugged into the phone socket?
- Check that the mains power is correctly connected to the base and to the handset charger(s).
- Only use the telephone cord supplied with the phone.

## **Cannot dial out or receive calls**

- Check that the mains power is correctly connected.
- The batteries may need recharging.
- Has there been a power cut? If so, place the handset back on the base for 10 seconds and try again. If it still does not work disconnect the batteries and mains power for 10 minutes, then reconnect and try again.

## **You have a dial tone, but the phone will not dial out**

- You may need to change the dial mode from tone to pulse, see page 25.
- If you are connected to a switchboard, check whether you need to dial an access code.

## **Handset does not ring**

- The ringer volume may be switched off, see page 22.
- Check that the mains power is correctly connected.
- Make sure the handset is registered to the base, see page 47.

### No display

- The batteries may be flat, dead or incorrectly inserted. Recharge or replace the batteries.

### Y icon flashes

- Is the handset registered correctly to the base, see page 47.
- Check that the mains power is correctly connected.
- Check that the handset is within range of the base.
- The batteries are low, place the handset on the base/charger to recharge.

### icon not scrolling

- Try cleaning the charging contacts.
- Check that the mains power is correctly connected.

### You hear the busy tone when you press .

- Make sure the handset is in range of the base.
- Another handset registered to your BT Synergy 5100 base may be on the line.

### No Caller Display number/name displayed

- Have you subscribed to a Caller Display service from your network provider, see page 33.
- The caller may have withheld their number.
- An exact name/number match was not found in your directory. Check that you have stored the full STD dialling code.

### **Cannot register a handset to a base**

- You can register a total of 5 handsets to your BT Synergy 5100 base and you can register your BT Synergy 5100 handset to up to 4 bases. Check that you have not exceeded the limits.
- Check that you have entered the correct PIN number (default PIN 0000).
- Check that you are at least one metre away from other electrical equipment to avoid interference when registering.

### **Base unit does not ring, but the lights are on**

- Have you connected the telephone line correctly?
- Is the base ringer set to off?
- You may have a faulty line or socket. Try using another socket or line. Call BT on 151 if you still experience problems.

### **Buzzing noise on my phone or on other electrical equipment nearby**

- Sometimes your BT Synergy 5100 can interfere with other electrical equipment if it is placed too close. It is recommended that you place your BT Synergy 5100 at least one metre away from electrical appliances or metal obstructions to avoid any risk of interference.

### **Customer Helpline**

If you are still experiencing difficulties please call the BT Synergy Helpline on 0800 145 6789\* or email [bt.helpdesk@sgweurope.com](mailto:bt.helpdesk@sgweurope.com).

---

## Possible problems with text messaging

You must subscribe to your network provider's Caller Display service for text messaging to work and you must not withhold your number. Your network provider may charge you for these services. Please note some other network provider lines may not be compatible with this text messaging service.

### Text messages cannot be sent and screen displays Message Sending Failed

- The base station power supply or telephone line cord might not be properly connected. Check that the base station power supply is plugged into the mains socket and switched on and that the telephone is plugged into the telephone wall socket.
- There might be a fault on the line. Check your telephone line is working properly.
- You might have deleted the server number in error. See page 45 for instructions on how to enter the number.

### Cannot send text

- Check service centre number is correct including 1470P prefix (this is for BT lines. If you have another network provider please check the prefix number with them). In order to send and receive text messages you must not withhold your number. If you normally withhold your number the 1470 prefix presents your number for you.

### Cannot receive text

- You will not be able to receive text messages until you have first sent a message. The first message sent registers you with the text service.
- More than one text messaging product is plugged into the line. Remove other products.
- Check service centre number is correct.
- Ensure you have subscribed to a Caller Display service and that it is active. You can check this by noting if your phone displays your caller's number when you receive an incoming call.
- If you are using personal user areas please ensure you have given people your user area number and that they are entering it to the end of your telephone number when sending you a text message.

**Text has previously been sent and received but you are now only receiving voice spoken text messages, from number 0845 6021111**

- This may be due to your line being de-registered at the text service centre. All you need to do is text RESET and send it to 00000. You will receive a confirmation message back.

This assumes that your Caller Display service is active and working on your line. Messages sent to 00000 are free.

**Further help and advice for text queries on BT lines:**

- BT Residential customers – call 151, choose option 2, when prompted by the Fault Management Service select option 2, enter your phone number on the handset and wait to speak to a customer adviser.
- BT Business Customers – call 152, choose option 2, when prompted by the Fault Management Service select option 2, enter your phone number on the handset and wait to speak to a customer adviser.
- For other telephone service providers please contact their customer services.

**General sales enquiries**

- BT Residential lines – call 150. BT Business lines – call 152.
- For non BT line customers, call 0800 800 150 (residential) or 0800 800 152 (business).
- Additional handsets are available from the Helpdesk on 0800 145 6789\*.

**Billing enquiries**

- Refer to the telephone number shown on your telephone bill.

**Other functions and services available from the text messaging service**

By sending the following commands to the BT text self administration facility you can control functions and capabilities in your text phone and the way messages are handled.

1. Press MENU and scroll to TEXT SETTINGS and press SELECT.
2. WRITE MESSAGE is highlighted. Press SELECT.

- 
3. Use the keypad to type in the following commands (depending upon what you want to do):

Opt out from receiving voice text messages.

Turns off the opt out option.

Turns on permanent voice text message delivery to your phone.

All incoming text is delivered as voice text.

Turns off permanent voice text message delivery.

4. Press **OPTIONS**. Display highlights **SEND**.
5. Enter the number 00000 then press **SEND**.

#### **If you are sending a message from a fixed line phone to another fixed line phone**

Forces a message you send to be delivered as a voice text even though the recipient may have a text enabled phone and usually receives written text. This command is inserted at the start of the message and applies only to that message, e.g. 'Hello I will be home late'.

#### **You keep hearing an error beep**

- You have pressed the wrong button in a sequence. Check the prompts in the display or refer to instructions in this user guide.

## IMPORTANT

This equipment is not designed for making emergency telephone call when the power fails. Alternative arrangements should be made for access to emergency services.

This product is intended for connection to analogue public switched telephone networks and private switchboards in the United Kingdom.

### Safety information

- Only use the power supply suitable for the BT Synergy 5100 range. Using an unauthorised power supply will invalidate your guarantee and may damage the telephone. The item code for the base mains power supply is 040497. The item code for the small mains power supply for the charger is 032765.
- Use only the approved rechargeable batteries supplied. Spare rechargeable batteries are available from the BT Synergy Helpline on 0800 145 6789\*. There is a risk of explosion if the batteries are replaced by an incorrect type.
- Do not open the handset (except to replace the handset batteries) or the base. This could expose you to high voltages or other risks. Contact the Helpline on 0800 145 6789\* for all repairs.
- Radio signal transmitted between the handset and base may cause interference to hearing aids.
- It is recommended that advice from a qualified expert be sought before using this product in the vicinity of emergency/intensive care medical equipment.
- It is recommended that if you have a pacemaker fitted you check with a medical expert before using this product.

- Your product may interfere with other electrical equipment, e.g. TV and radio sets, clock/alarms and computers if placed too close. It is recommended that you place your product at least one metre away from such appliances to minimise any risk of interference.
- Never dispose of batteries in a fire. There is a serious risk of explosion and/or the release of highly toxic chemicals. Dispose of batteries according to the instructions.

### Cleaning

- Clean the handset and base (or charger) with a damp (not wet) cloth, or an anti-static wipe.
- Never use household polish as this will damage the product. Never use a dry cloth as this may cause a static shock.

### Environmental

- Do not expose to direct sunlight.
- The handset may become warm when the batteries are being charged or during prolonged periods of use. This is normal. However, we recommend that to avoid damage you do not place the product on antique/veneered wood.
- Do not stand your product on carpets or other surfaces which generate fibres, or place it in locations preventing the free flow of air over its surfaces.
- Do not submerge any part of your product in water and do not use it in damp or humid conditions, such as bathrooms.
- Do not expose your product to fire, explosive or other hazardous conditions.
- There is a slight chance your phone could be damaged by an electrical storm. We recommend that you unplug the power and telephone line cord during an electrical storm.

## Product disposal instructions



The symbol shown here and on the product means that the product is classed as Electrical or Electronic Equipment and should not be disposed with other household or commercial waste at the end of its working life.

The Waste of Electrical and Electronic Equipment (WEEE) Directive (2002/96/EC) has been put in place to recycle products using best available recovery and recycling techniques to minimize the impact on the environment, treat any hazardous substances and avoid the increasing landfill.

### Product disposal instructions for residential users

When you have no further use for it, please remove any batteries and dispose of them and the product as per your local authority's recycling processes. For more information please contact your local authority or the retailer where the product was purchased.

### Product disposal instructions for business users

Business users should contact their suppliers and check the terms and conditions of the purchase contract and ensure that this product is not mixed with other commercial waste for disposal.

## Guarantee

Your BT Synergy 5100 is guaranteed for a period of 12 months from the date of purchase.

Subject to the terms listed below, the guarantee will provide for the repair of, or at BT's or its agent's discretion, the option to replace the BT Synergy 5100 or any component thereof, (other than batteries), which is identified as faulty or below standard, or as a result of inferior workmanship or materials. Products over 28 days old from the date of purchase may be replaced with a refurbished or repaired product.

### The conditions of this guarantee are:

- The guarantee shall only apply to defects that occur within the 12 month guarantee period.
- Proof of purchase is provided.
- The equipment is returned to BT or its agent as instructed.
- This guarantee does not cover any faults or defects caused by accidents, misuse, fair wear and tear, neglect, tampering with the equipment, or any attempt at adjustment or repair other than through approved agents.
- This guarantee does not affect your statutory rights.

### Within the 12 month guarantee period:

Prior to returning your product, please read the Help section beginning on page 50 or contact the Helpline on 0800 145 6789\* or email [bt.helpdesk@sgweurope.com](mailto:bt.helpdesk@sgweurope.com) for assistance. In the unlikely event of a defect occurring, please follow the Helpline's instructions for replacement or repair.

### Outside of the 12 month guarantee period:

If your product needs repair after the guarantee period has ended, the repair must meet the approval requirements for connection to the telephone network.

We recommend that you contact BT's approved repair agent Helpdesk Solutions on 0870 240 5029 or a local qualified repairer.

For guarantee purposes proof of purchase is required so please keep your receipt.

### Returning your phone

If the Helpline is unable to remedy your problem they will ask you to return the product. Where possible, pack the product in its original packaging. Please remember to include all parts, including the line cords, power supply units and the original batteries. (Please note that we cannot take responsibility for goods damaged in transit). Please obtain and keep proof of posting from the Post Office.

## Technical information

### How many telephones can I have?

All items of telephone equipment have a Ringer Equivalence Number (REN), which is used to calculate the number of items which may be connected to any one telephone line. Your BT Synergy 5100 has a REN of 1. A total REN of 4 is allowed. If the total REN of 4 is exceeded, the telephones may not ring. With different telephone types there is no guarantee of ringing, even when the REN is less than 4.

Any additional handsets and chargers that you register have a REN of 0.

## R&TTE

This product is intended for use within the UK for connection to the public telephone network and compatible switchboards.

This equipment complies with the essential requirements for the Radio Equipment and Telecommunications Terminal Equipment Directive 1999/5/EC.

### Declaration of Conformance

Hereby, Suncorp Technologies declares that this BT Synergy 5100 is in compliance with the essential requirements and other relevant provisions of Directive 1999/5/EC.

The Declaration of Conformance for the BT Synergy 5100 is published on the website: <http://www.sgweurope.com/bt>

### Connecting to a switchboard

This product is intended for use within the UK for connection to the public telephone network and compatible switchboards, which support tone and pulse dialling and timed break recall. If in doubt please consult your service provider.

### Inserting a pause

With some switchboards, after dialling the access code you may have to wait for a moment while the switchboard picks up an outside line so you will need to enter a pause in the dialing sequence.

Press and hold  to insert a pause (P) before entering the telephone number.

You may also need to enter a pause when storing international numbers or charge card numbers.

### Recall

You may need to use the recall function if you are connected to a switchboard/PBX (Private Branch Exchange), contact your PBX supplier for further information. The recall function is set to timed break recall and is also used for BT Calling Feature.



Working together, supporting energy saving products

BT & British Gas have joined forces to help our customers find new ways to save energy around the home, so we can all do our bit for the environment & save money too!

BT is a **sustainability leader**

{ To find out how we're  
making our products  
greener visit

[bt.com/betterworld/products](http://bt.com/betterworld/products) 

### Offices worldwide

The services described in this publication are subject to availability and may be modified from time to time. Services and equipment are provided subject to British Telecommunications plc's respective standard conditions of contract. Nothing in this publication forms any part of any contract.

© British Telecommunications plc 2008.  
Registered Office: 81 Newgate Street, London EC1A 7AJ.  
Registered in England No. 1800000.

Designed and produced by The Art & Design Partnership Ltd.

BT Synergy 5100 (11/08) Issue 1

